

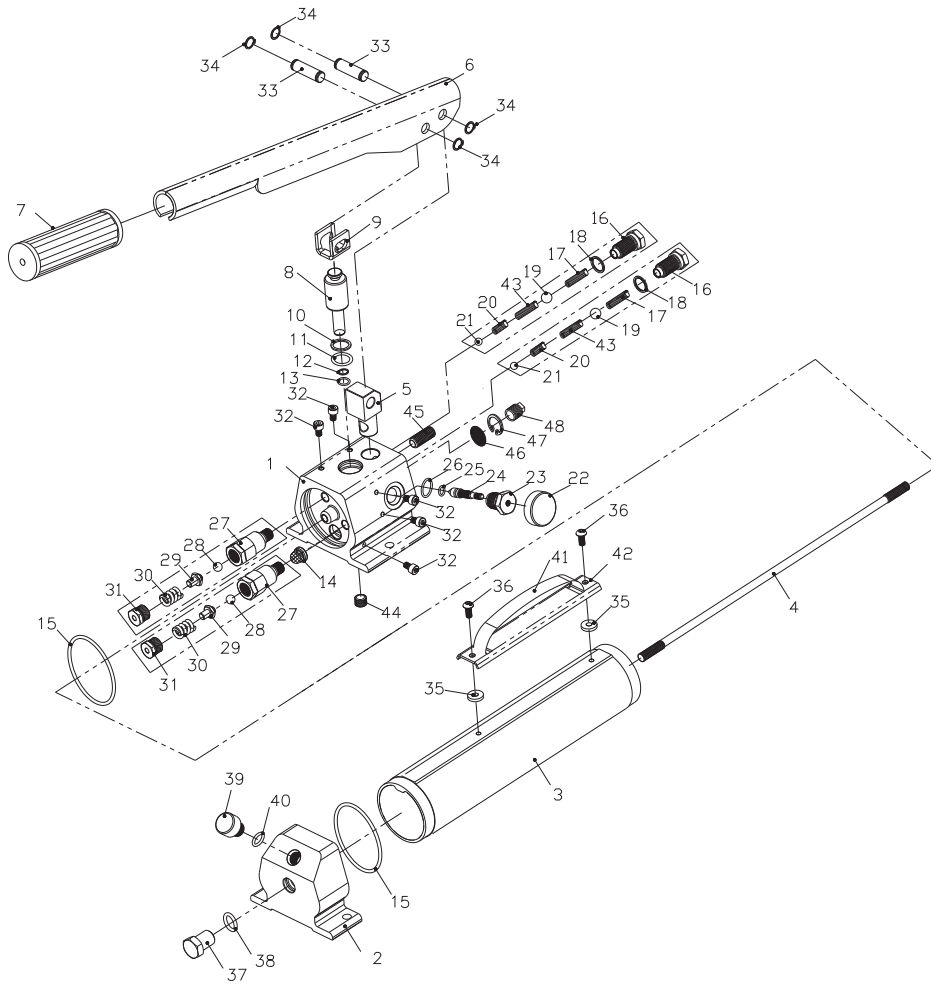

ZHP-20A ~ ZHP-55A Aluminum Hand Pumps -Parts Breakdown

Toll Free: 1-800-579-8088 Web: www.zinko.com

REV 102408



#	Description
1	Hydraulic Pump
2	Oil Cover Base
3	Aluminum Oil Tube
4	Axle
5	Base Axle
6	Operation Axle
7	Handle Bar Bush
8	Piston
9	Piston Ring
10	Backup Ring
11	O-Ring
12	Backup Ring
13	O-Ring
14	Filter
15	O-Ring
16	Bolt

#	Description
17	Spring
18	Washer
19	Steel Ball
20	Spring
21	Steel Ball
22	Valve Bar
23	Release Valve
24	Release Valve Axle
25	O-Ring
26	O-Ring
27	Valve Cartridge
28	Steel Ball
29	Axle
30	Spring
31	Screw
32	Bolt

#	Description
33	Axle
34	C-Ring
35	Washer
36	Bolt
37	Bolt
38	O-Ring
39	Oil Inlet Bolt
40	O-Ring
41	Hand Bar
42	Hand Bar Cover
43	Spring
44	Bolt
45	Screw
46	Filter
47	C-Ring
48	Bolt